

Rebuild/Repack Kits for Flowrite™ VF 599 Series 1/2 to 2-inch Valves

Product Description

This kit contains the parts necessary to rebuild and repack the Flowrite VP 599 Series 1/2 to 2-inch Valves.



Contents

- Packing cartridge assembly kit cartridge, copper gasket, and instructions
- Stem and plug assembly
- One O-ring
- Two tubes of silicone lubricant
- Instructions

Product Numbers

599-03300 through 599-03389

Warning/Caution Notations

WARNING:		Personal injury, or loss of life may occur if you do not perform a procedure as specified.
CAUTION:		Equipment damage, or loss of data may occur if you do not follow a procedure as specified.

Required Tools

- Tools for removing the actuator. These tools are listed on the installation instructions included in the packing cartridge assembly kit.
- 1-1/16 inch open end wrench
- Adjustable wrench

Expected Installation Time

45 minutes for normally open (NO) valves
60 minutes for normally closed (NC) valves
60 minutes for three-way valves

Table 1. Wrench Sizes in Inches (Millimeters).

Line Size	NO Bonnet	NC Cap	3-Way Lower Port	Union Nut
1/2 (15)	N/A	1-3/8 (≈35)	1-7/16 (≈37)	1-1/2 (≈39)
3/4 (20)	1-3/4 (≈45)	1-5/8 (≈42)	1-11/16 (≈43)	1-7/8 (≈48)
1 (25)	2 (≈51)	2 (≈51)	2 (≈51)	2-1/8 (≈54)
1-1/4 (32)	2 (≈51)	2-1/4 (≈58)	2-7/16 (≈62)	2-3/4 (≈70)
1-1/2 (40)	2-5/8 (≈67)	2-5/8 (≈67)	2-5/8 (≈67)	3 (≈77)
2 (50)	3-1/8 (≈80)	3-1/8 (≈80)	3-1/4 (≈83)	3-1/2 (≈89)

Prerequisites

Open the packing cartridge assembly kit and remove the installation instructions. These instructions explain how to remove and reassemble each type of actuator and list the tools needed.

We recommend rebuilding and repacking the valve at a bench and not in line.



WARNING:

Isolate the valve so that the medium (water, steam, etc.) will not leak out of the valve when the valve body is disassembled.



WARNING:

Remove and cap the air line or disconnect the power to the actuator before removing the actuator from the valve.

Installation

1/2-inch normally open valves

Removing the Packing and the Stem and Plug Assembly. (See Figure 1.)

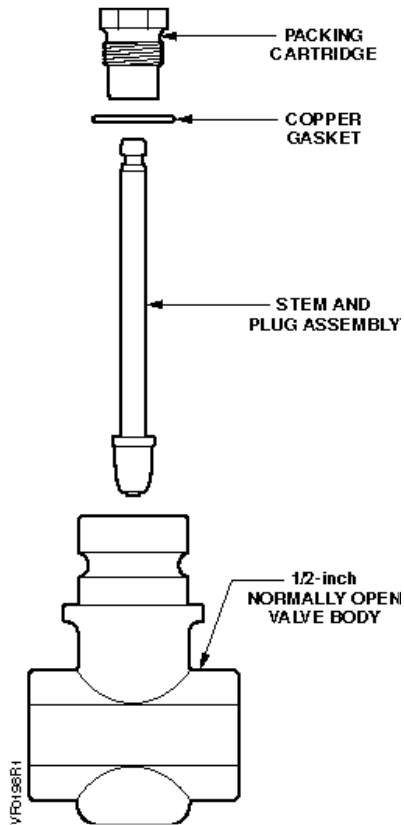

Figure 1. Normally Open 1/2-inch Valve.

1. Remove the actuator by following the instructions included in the packing cartridge kit.
2. Remove and discard the packing cartridge using a 1-1/16 inch wrench.
3. Remove and discard the copper gasket (the gasket cannot be reused). Clean the gasket surface of the valve.
4. Remove and discard the stem and plug assembly (the assembly cannot be reused).
5. Examine the valve seat surface for nicks and scratches. Replace the valve if the seat is damaged.

Replacing the Stem and Plug Assembly and Packing

1. Place the new copper gasket on the valve bonnet.
2. Insert the new stem and plug assembly into the valve body.



CAUTION:

Be careful not to nick the seat. The valve must be replaced if the seat is damaged.

3. Insert the new packing cartridge into the valve bonnet. Use a 1-1/16 inch wrench to tighten the cartridge applying 35 to 40 lb-ft (47 to 54 Nm) torque.
4. Assemble the actuator to the valve using the instructions in the packing cartridge kit.

3/4- to 2-inch normally open valves

Removing the Packing and the Stem and Plug Assembly. (See Figure 2.)

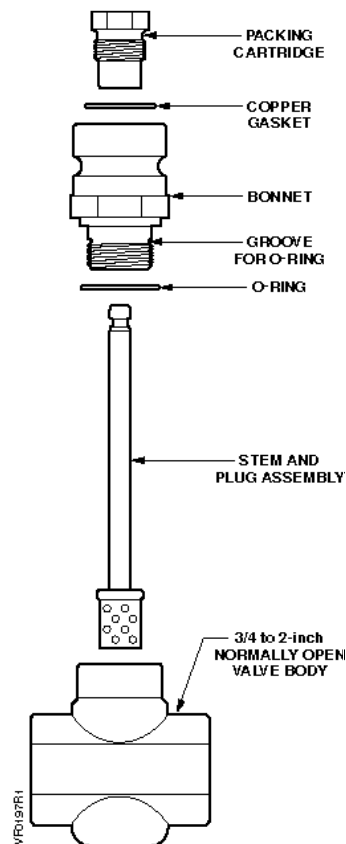

Figure 2. Normally Open 3/4- to 2-inch Valves.

1. Remove the actuator by following the instructions included in the packing cartridge kit.
2. Remove and discard the packing cartridge using a 1-1/16 inch wrench.
3. Remove and discard the copper gasket (the gasket cannot be reused). Clean the gasket surface of the valve.
4. Remove and save the bonnet using an adjustable wrench.

Installation, Continued

5. Remove and discard the stem and plug assembly.
6. Examine the valve seat surface for nicks and scratches. Replace the valve if the seat is damaged.
7. Remove the O-ring from the bonnet. Clean the O-ring groove. Make sure none of the O-ring material remains in the valve.



WARNING:

Bonnet threads are sharp! Either wear gloves for protection, or handle with caution.

Replacing the Stem and Plug Assembly and Packing.

1. Insert the new stem and plug assembly into the valve body.



CAUTION:

Be careful not to nick the seat. The valve must be replaced if the seat is damaged.

2. Manually coat the O-ring with the silicone lubricant provided. You may need to use both tubes of lubricant.
3. Slip the O-ring into the groove of the bonnet.
4. Carefully place the bonnet into the valve body without damaging the stem.
5. Tighten the bonnet in place applying 45 to 55 lb-ft (61 to 75 Nm) torque, using an adjustable wrench
6. Place the new copper gasket on the valve bonnet.
7. Insert the new packing cartridge into the valve bonnet. Use a 1-1/16 inch wrench to tighten the cartridge applying 35 to 40 lb-ft (47 to 54 Nm) torque.
8. Assemble the actuator to the valve using the instructions in the packing cartridge kit.

Normally closed valves

Removing the Packing and the Stem and Plug Assembly. (See Figure 3.)

1. Remove the actuator by following the instructions included in the packing cartridge kit.

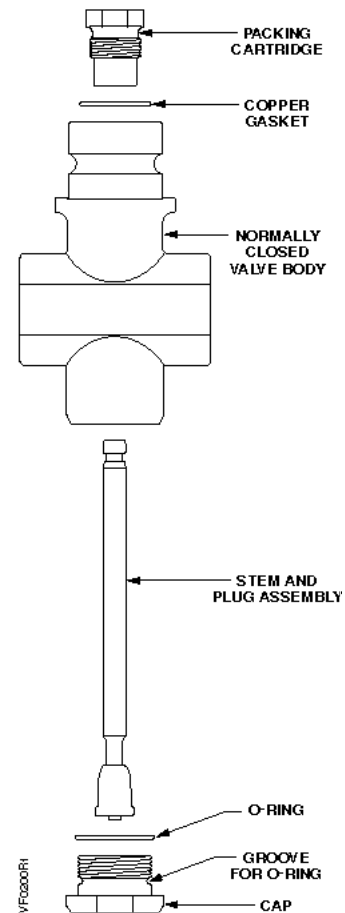

Figure 3. Flowrite 599 Series Normally Closed Valve.

2. Remove and discard the packing cartridge using a 1-1/16 inch wrench.
3. Remove and discard the copper gasket (the gasket cannot be reused). Clean the gasket surface of the valve.
4. Remove and save the cap using an adjustable wrench.
5. Remove and discard the stem and plug assembly.
6. Examine the valve seat surface for nicks and scratches. Replace the valve if the seat is damaged.
7. Remove the O-ring from the cap. Clean the O-ring groove. Make sure none of the O-ring material remains in the valve.

Installation, Continued



WARNING:

Cap threads are sharp! Either wear gloves for protection, or handle with caution.

Replacing the Stem and Plug Assembly and Packing.

1. Manually coat the O-ring with the silicone lubricant provided. You may need to use both tubes of lubricant.
2. Slip the O-ring into the groove of the cap.
3. Insert the new stem and plug assembly into the valve body.



CAUTION:

Be careful not to nick the seat. The valve must be replaced if the seat is damaged.

4. Place the cap on the valve, and use an adjustable wrench to tighten the cap applying 45 to 55 lb-ft (61 to 75 Nm) torque.
5. Place the new copper gasket on the valve bonnet.
6. Insert the new packing cartridge into the valve. Use a 1-1/16 inch wrench to tighten the cartridge applying 35 to 40 lb-ft (47 to 54 Nm) torque.
7. Assemble the actuator to the valve using the instructions in the packing cartridge kit.

Three-way valves

Removing the Packing and the Stem and Plug Assembly. (See Figure 4.)

1. Remove the actuator by following the instructions included in the packing cartridge kit.
2. Remove and discard the packing cartridge using a 1-1/16 inch wrench.
3. Remove and discard the copper gasket (the gasket cannot be reused). Clean the gasket surface of the valve.
4. Using an adjustable wrench, remove and save the lower port.
5. Remove and discard the stem and plug assembly (the assembly cannot be reused).

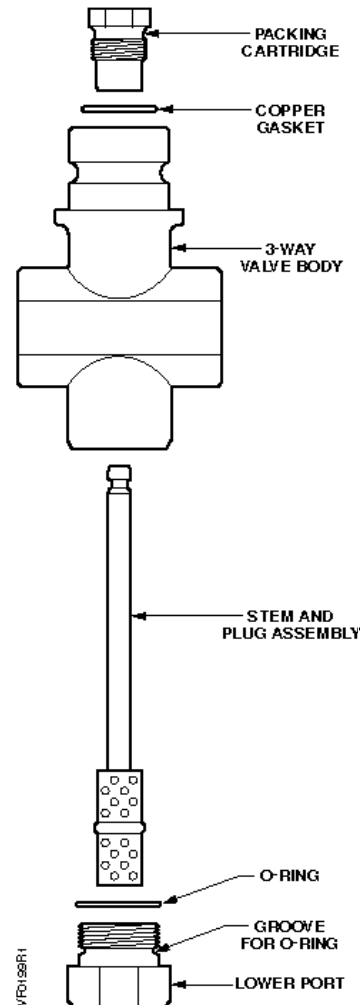

Figure 4. Flowrite 599 Series Three-Way Valve.

6. Examine the valve seat surface for nicks and scratches. Replace the valve if the seat is damaged.
7. Remove the O-ring from the lower port. Clean the O-ring groove. Make sure none of the O-ring material remains in the valve.



WARNING:

Lower port threads are sharp! Either wear gloves for protection, or handle with caution.

Replacing the Stem and Plug Assembly and Packing.

1. Manually coat the O-ring with the silicone lubricant provided. You may need to use both tubes of lubricant.
2. Slip the O-ring into the groove of the cap.

Installation, Continued

3. Insert the new stem and plug assembly into the valve body.



CAUTION:

Be careful not to nick the seat or scratch the valve stem. The valve must be replaced if the seat is damaged.

4. Place the lower port on the valve, and use an adjustable wrench to tighten the lower port applying 45 to 55 lb-ft (61 to 75 Nm) torque.

5. Place the new copper gasket on the valve bonnet.
6. Insert the new packing cartridge into the valve. Use a 1-1/16 inch wrench to tighten the cartridge applying 35 to 40 lb-ft (47 to 54 Nm) torque.
7. Using the instructions in the packing cartridge kit, assemble the actuator to the valve.

The installation is now complete.

Information in this publication is based on current specifications. The company reserves the right to make changes in specifications and models as design improvements are introduced. Flowrite is a registered trademark of Siemens Industry, Inc.. Product or company names mentioned herein may be the trademarks of their respective owners. © 2009 Siemens Industry, Inc.